

# A230 Ultrasonic Air-in-Line / Bubble Detector

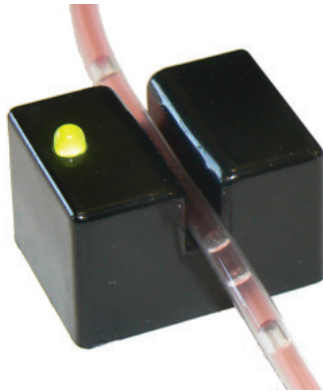

The A230 Air-In-line/Bubble Detector is one of our standard sensors for use with most tubing between 3 and 4 mm OD. It uses our proprietary digital non-invasive ultrasonic bubble sensing technology to accurately and reliably detect bubbles in a wide variety of fluids and tubing materials.

Custom characteristics can be provided for OEM users.

## FEATURES

- Integrated self-test function
- Low power consumption (<10 mA @5V)
- Dry-couples with a variety of tubing materials
- Custom pinouts, cables, and connectors available
- Digital "smart" circuit for superior customizability
- Non-invasive ultrasonic bubble sensing technology
- Red/Green LED for visual indication of sensor output

## DIMENSIONAL DRAWING

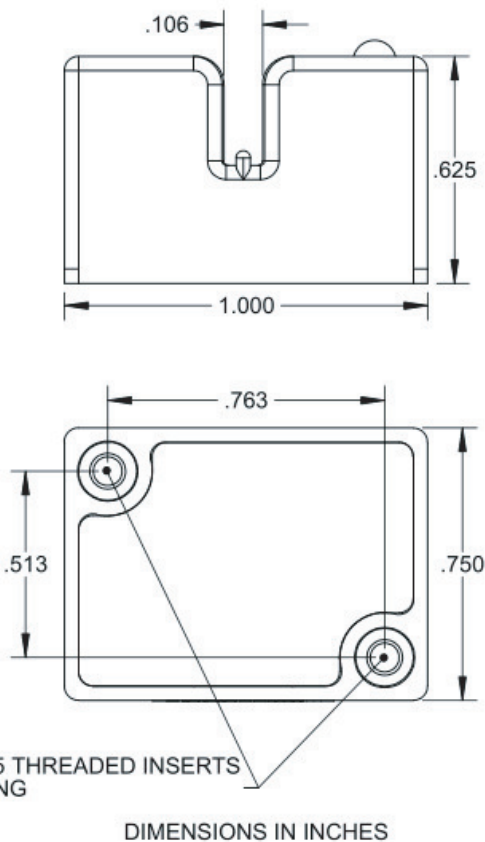

## SPECIFICATIONS

Tube Size	1/8" OD Nominal
Bubble Size	Customer Selectable
Sensor Input	5-12 VDC (<10 mA)
Sensor Output	5 V Water / 0 V Air
Response Time	50 microseconds Typical
Lead Out	Red 5-12 VDC
	Black Ground
	Green Output
	White Test (Optional)

Part Name	Description
A230-SL	A230 Bubble sensor with standard (#4-40) threaded inserts
A230-ML	A230 Bubble Sensor with Metric (M2.5) Threaded Inserts